



POST HOLE DIGGER

OPERATION AND ASSEMBLY MANUAL

INTRODUCTION

TO THE OWNER:

Read this manual before operating your equipment. Keep this manual handy for ready reference. Require all operators to read this manual carefully and become acquainted with all adjustments and operating procedures before attempting to operate the equipment. Replacement manuals can be obtained from your selling dealer.

The equipment you have purchased has been carefully engineered and manufactured to provide dependable and satisfactory use. Like all mechanical products, it will require cleaning and upkeep. Lubricate the unit as specified. Please observe all safety information in this manual and safety decals on the equipment.

Use only genuine service parts. Substitute parts will void the warranty and may not meet the required standards for safe and satisfactory operation.

Throughout this manual, the term **IMPORTANT** is used to indicate that failure to observe procedures can cause damage to equipment. The terms **CAUTION**, **WARNING** and **DANGER** are used in conjunction with the Safety-Alert Symbol, (a triangle with an exclamation mark), to indicate the degree of hazard for items of personal safety.



This Safety-Alert Symbol indicates a hazard and means ATTENTION! BECOME ALERT! YOUR SAFETY IS INVOLVED!



DANGER

Indicates an imminently hazardous situation that, if not avoided, will result in death or serious injury.



WARNING

Indicates a potentially hazardous situation that, if not avoided, could result in death or serious injury, and includes hazards that are exposed when guards are removed.



CAUTION

Indicates a potentially hazardous situation that, if not avoided, may result in minor or moderate injury.

IMPORTANT

Indicates that failure to observe can cause damage to equipment.

NOTE

Indicates helpful information.

IT IS THE PURCHASER AND/OR OPERATOR'S RESPONSIBILITY TO....

Read and understand the information contained in this manual.

Operate, lubricate, assemble and maintain the equipment in accordance with all instructions and safety procedures in this manual.

Inspect the equipment and replace or repair any parts that are damaged or worn which under continued operation would cause damage, wear to other parts, or cause a safety hazard.

Return the equipment or parts to the authorized dealer, from where it was purchased, for service or replacement of defective parts that are covered by warranty. (Manufacturer may inspect equipment or parts before warranty claims are honored.)

Payment of all costs incurred by the dealer for traveling to or transporting the equipment for warranty inspection and or claims.

Safety.....	4-7
Safety & Instruction Decals	8-9
Assembly & Setup	10-12
Attaching.....	13
Detaching.....	14
Sizing PTO	14
Operating.....	15
Maintenance.....	15
Parts	16

All information, illustrations and specifications in this manual are based on the latest information available at the time of publication. The right is reserved to make changes at any time without notice.

TO THE PURCHASER:

This manual contains valuable information about your new Post Hole Digger. It has been carefully prepared to give you helpful suggestions for operating, adjusting, servicing and ordering repair parts.

Keep this manual in a convenient place for quick and easy reference. Study it carefully. You have purchased a dependable and sturdy post hole digger, but only by proper care and operation can you expect to receive the service and long life designed and built into it.

Sometime in the future your post hole digger may need new parts to replace those that are worn or broken. If so, go to your dealer and provide him with the model and part number.

CUSTOMER INFORMATION

Name _____

Purchased From _____

Date Purchased _____

Model No. _____

Serial No. _____

TRAINING

Safety is a primary concern in the design and manufacturing of our product. Unfortunately, our efforts to provide safe equipment can be wiped out by a single careless act of an operator or bystander.

In addition to the design and configuration of equipment, hazard control and accident prevention are dependent upon the awareness, concern, prudence and proper training of personnel involved in the operation, transport, maintenance and storage of this equipment.

It has been said, "The best safety device is an informed, careful operator." We ask you to be that kind of operator. It is the operator's responsibility to read and understand all safety and operating instructions in the manual and to follow them. Accidents can be avoided.

Working with unfamiliar equipment can lead to careless injuries. Read this manual, and the manual for your tractor, before assembly or operating, to acquaint yourself with the machines. If this machine is used by any person other than you, or is loaned or rented, it is the post hole digger owner's responsibility to make certain that the owner's manual be available to the operator prior to operating:

- 1.) Reads and understands the operator's manuals.
- 2.) Is instructed in safe and proper use.

Know your controls and how to stop the tractor, engine, and post hole digger quickly in an emergency. Read this manual and the one provided with your tractor.

Train all new personnel and review instructions frequently with existing workers. Be certain only a properly trained and physically able person will operate the machinery. A person who has not read and understood all operating and safety instructions is not qualified to operate the machine. An untrained operator exposes himself and bystanders to possible serious injury or death. If the elderly are assisting with farm work, their physical limitations need to be recognized and accommodated.

PREPARATION

Never operate the tractor and post hole digger until you have read and completely understand this manual, the Tractor Operator's Manual, and each of the safety messages found on the safety signs on the tractor and post hole digger.

Personal protection equipment including hard hat, safety glasses, safety shoes, and gloves are recommended during assembly, installation, operation, adjustment, maintenance, repairing, removal, or moving the implement. Do not allow long hair, loose fitting clothing, or jewelry to be around equipment.

PROLONGED EXPOSURE TO LOUD NOISE MAY CAUSE PERMANENT HEARING LOSS! Tractors with or without post hole diggers attached can often be noisy enough to cause permanent, partial hearing loss. We recommend that you wear hearing protection on a full time basis if the noise in the operator's position exceeds 80 db. Noise over 80 db on a long-term basis can cause severe hearing loss. Noise over 90 db adjacent to the operator over a long-term basis may cause permanent, total hearing loss.

NOTE: Hearing loss from loud noise (from tractors, chain saws, radios, and other such sources close to the ear) is cumulative over a lifetime without hope of natural recovery.

Operate the post hole digger only with a tractor equipped with an approved Roll-Over-Protective System (ROPS). Always wear your seat belt. Serious injury or even death could result from falling off the tractor — particularly during a turnover when the operator could be pinned under the ROPS or the tractor.

Clear digging area of stones, branches or other debris that might be thrown or entangled in the post hole digger, causing injury or damage.

Operate only in daylight or good artificial light.

Ensure post hole digger is properly mounted, adjusted and in good operating condition.

Ensure that all safety shielding and safety signs are properly installed and in good condition.

STARTING AND STOPPING

Check the tractor master shield over the PTO stub shaft. Make sure it is in good condition and fastened securely to the tractor. Purchase a new shield if old shield is damaged or missing.

All tractors that are not equipped with a "live" power takeoff (PTO) need to be equipped with an over-running PTO clutch. These are available through most farm equipment stores.

(continued on next page)

(continued from previous page)

NOTE: The addition of an over-running PTO clutch may change the length of the PTO driveline required. Pay extra attention to the instructions on the PTO Driveline Installation. Be sure that the driveline system guarding is adequate.

Post hole digger operating power is supplied from the tractor PTO. Refer to your tractor manual for PTO engagement and disengagement instructions. Know how to stop tractor and post hole digger quickly in case of an emergency.

When engaging PTO, the engine RPM should always be at idle speed. Once engaged and ready to start digging, raise PTO speed to 540 RPM and increase speed as the auger goes deeper.

OPERATION

The use of this equipment is subject to certain hazards that cannot be protected against by the mechanical means or product design. All operators of this equipment must read and understand this entire manual, paying particular attention to safety and operating instructions, prior to using. If there is something in this manual you do not understand, ask your supervisor, or your dealer, to explain it to you.

Most accidents occur because of neglect or carelessness. Keep all helpers and bystanders at least several hundred feet from an operating post hole digger. Only properly trained people should operate this machine.

When machine is operated in populated areas where thrown objects could injure persons or property, operation must be stopped when anyone comes within several hundred feet.

The majority of the accidents involve entanglement on the driveline, injury of bystanders by the objects thrown by the rotating auger, and operators being knocked off the tractor by low hanging limbs and then being injured by the equipment. Accidents are most likely to occur with machines that are loaned or rented to someone who has not read the owner's manual and is not familiar with a post hole digger.

The post hole digger is designed for use only on tractors with the power takeoff (PTO) turning at 540 RPM.

Install and secure all guards and shields before starting or operating. The post hole digger, driveline guards and tractor,

shields should be used and maintained in good working condition. They should be inspected carefully, at least daily, for missing or broken chain links, shields, or guards. (Worn items must be replaced at once to reduce possibility of injury.)

Disengage power takeoff (PTO) and place transmission in neutral before attempting to start engine.

Many varied objects, such as wire, cable, rope, or chains, can become entangled in the operating parts of the post hole digger. These items could then swing outside the housing at greater velocities than the auger. Such a situation is extremely hazardous. Inspect the digging area for such objects before digging. Remove any like objects from the site.

Never allow the auger to contact such items. Never assume an area is clear. Always Check!

Always stop the tractor, disengage PTO, set brake, shut off the tractor engine, remove the ignition key, lower implement to the ground and allow rotating pieces to come to a complete stop before dismounting tractor. Never leave equipment unattended with the tractor running.

Never place hands or feet under post hole digger with tractor engine running or before you are sure all motion has stopped. Stay clear of all moving parts.

Do not reach or place any part of your body under equipment until it is properly secured.

Do not allow riders on the post hole digger or tractor at anytime. There is no safe place for any riders.

Do not operate unless all personnel, livestock, and pets are several hundred feet away to prevent injury by thrown objects.

Never operate tractor and post hole digger under trees with low hanging limbs. Operators can be knocked off the tractor and then hit by equipment.

The rotating parts of this machine have been designed and tested for rugged use. However, they could fail upon impact with heavy, solid objects such as steel guardrails and concrete abutment. Such impact could cause the broken objects to be thrown outward at very high velocities. To reduce the possibility of property damage, serious injury, or even death, never allow the auger to contact such obstacles.

(continued on next page)

(continued from previous page)

Stop post hole digger and tractor immediately upon striking an obstruction. Turn engine off, remove key, inspect and repair any damage before resuming operation.

Stay alert for uneven terrain, holes, rocks, and roots and other hidden hazards. Keep away from drop-offs and hazards that could cause roll over. Use extreme care and maintain minimum ground speed when transporting or operating on hillsides, over rough ground and when operating close to ditches or fences. Be careful and slow down when turning sharp corners and changing direction on slopes. Do not start or stop suddenly on slopes. Avoid operation on steep slopes. In extremely uneven terrain, rear wheels weights, front tractor weight, and/or tire ballast should be used to improve stability.

Pass post hole digger diagonally through sharp dips and avoid sharp drops to prevent "hanging up" tractor and post hole digger. Practice will improve your skills in maneuvering on rough terrain. Always cut down slopes, never across the face. Always check tractor manual for proper use on slopes.

When using a unit, a minimum 20% of tractor and equipment weight must be on tractor front wheels. Without this weight, tractor could tip over, causing personal injury or death. The weight may be attained with a front end loader, front wheel weights, ballast in the tires or front tractor weights. When attaining a minimum 20% of tractor and equipment weight on the front wheels, you must not exceed the ROPS weight certification. Weigh the tractor and equipment. Do not guess or estimate!

TRANSPORTATION

Comply with state and local laws governing highway safety and movement of farm machinery on public roads.

The use of flashing amber lights is acceptable in most localities. However, some localities prohibit their use. Local laws should be checked for all lighting and marking requirements.

At all times, when driving the tractor and equipment on the road or highway under 20 mph (32 kph) use flashing amber warning lights and a slow moving vehicle (SMV) identification emblem. Do not exceed 20 mph (32 kph). Reduce speed on rough roads and surfaces.

Plan your route to avoid heavy traffic.

Always install transport locks, pins or brackets before transporting.

Do not drink and drive.

Be a safe and courteous driver. Always yield to oncoming traffic in all situations, including narrow bridges, intersections, etc. Watch for traffic when operating near or crossing roadways.

Turn curves or go up or down hills only at a low speed and at a gradual steering angle. Make certain that a least 20% of the tractor's weight is on the front wheels to maintain safe steering. Slow down on rough or uneven surface. Always check tractor manual for proper use on slopes.

Use extreme care and maintain minimum ground and when operating close to ditches or fences. Be careful when turning sharp corners.

Never allow riders on either tractor or post hole digger.

MAINTENANCE

Good maintenance is your responsibility. Poor maintenance is an invitation to trouble.

Follow good shop practices.

Keep service area clean and dry

Be sure electrical outlets and tools are properly grounded

Use adequate light for the job at hand.

Make sure there is plenty of ventilation. Never operate the engine of the towing vehicle in a closed building. The exhaust fumes may cause asphyxiation.

Before working on this machine, disengage the PTO, shut off the engine, set the brakes, and remove the ignition keys.

Be certain all moving parts on attachments have come to a complete stop before attempting to perform maintenance.

Never work under equipment unless it is blocked securely.

Always use personal protection devices such as eye, hand and hearing protectors, when performing any service or maintenance.

Frequently check the post hole digger auger. It should be free of nicks, cracks, and securely fastened.

(continued on next page)

(continued from previous page)

Periodically tighten all bolts, nuts, and screws and check that all cotter pins are properly installed to ensure unit is in safe condition.

When completing a maintenance or service function, make sure all safety shields and devices are installed before placing unit in service.

After servicing, be sure all tools, parts and service equipment are removed from post hole digger.

Do not allow debris, grease or oil to build up on the post hole digger.

When replacement parts are necessary for periodic maintenance and servicing, genuine factory replacement parts must be used to restore your equipment to original specifications.

The manufacturer will not be responsible for injuries or damages caused by use of unapproved parts and/or accessories.

A fire extinguisher and the first aid kit should be kept readily accessible while performing maintenance on this equipment.

STORAGE

Following operation, or when unhooking the post hole digger, stop the tractor, set the brakes, disengage the PTO, shut off the engine and remove the ignition keys.

Store the unit in an area away from human activity.

Do not park equipment where it can be exposed to direct contact to livestock for long periods of time. Damage and livestock injury could result.

Make sure all parked machines are on a hard, level surface and engage all safety devices.

EQUIPMENT SAFETY GUIDELINES

Safety of the operator and bystanders is one of the main concerns in designing and developing a post hole digger. However, every year accidents occur which could have been avoided by a few seconds of thought and a more careful approach to handling equipment. You, the operator, can avoid many accidents by observing the following precautions and insist those working with you, or for you, follow them.

In order to provide a better view, certain photographs or illustrations in this manual may show an assembly with a safety shield removed. However, equipment should never be operated in this condition. Keep all shields in place. If shield removal becomes necessary for repairs, replace the shield prior to use.

Replace any safety sign that is not readable or missing. Location of such safety signs are indicated in this manual.

Never use alcoholic beverages or drugs that can hinder alertness or coordination while operating this equipment. Consult your doctor about operating this machine while taking prescription medications.

Under no circumstances should children under the age of 18 be allowed to work with this equipment. Do not allow persons to operate or assemble this unit until they have read this manual and have developed a thorough understanding of the safety precautions and how it works. Review the safety instructions with all users annually.

This equipment is dangerous to children and persons unfamiliar with its operation. The operator should be a responsible, properly trained and physically able person familiar with farm machinery and trained in this equipment's operations. If the elderly are assisting with farm work, their physical limitations need to be recognized and accommodated.

Use a tractor equipped with a Roll Over Protective System and seat belts. (ROPS)

Never exceed the limits of a piece of machinery. If its ability to do a job, or to do so safely, is in question – DON'T TRY IT.

Do not modify the equipment in any way. Unauthorized modification could result in serious injury or death and may impair the function and life of the equipment.

In addition to the design and the confirmation of this implement, including safety signs and safety equipment, hazard control and accident prevention are dependent upon the awareness, concern, prudence, and proper training of personnel involved in the operation, transport, maintenance, and storage of the machine. Refer also to safety messages and operation instruction in each of the appropriate sections of the tractor and post hole digger manuals. Pay close attention to the safety signs affixed to the tractor and the post hole digger.

SAFETY AND INSTRUCTION DECALS

ATTENTION! BECOME ALERT! YOUR SAFETY IS INVOLVED!
Replace Immediately if Damaged!

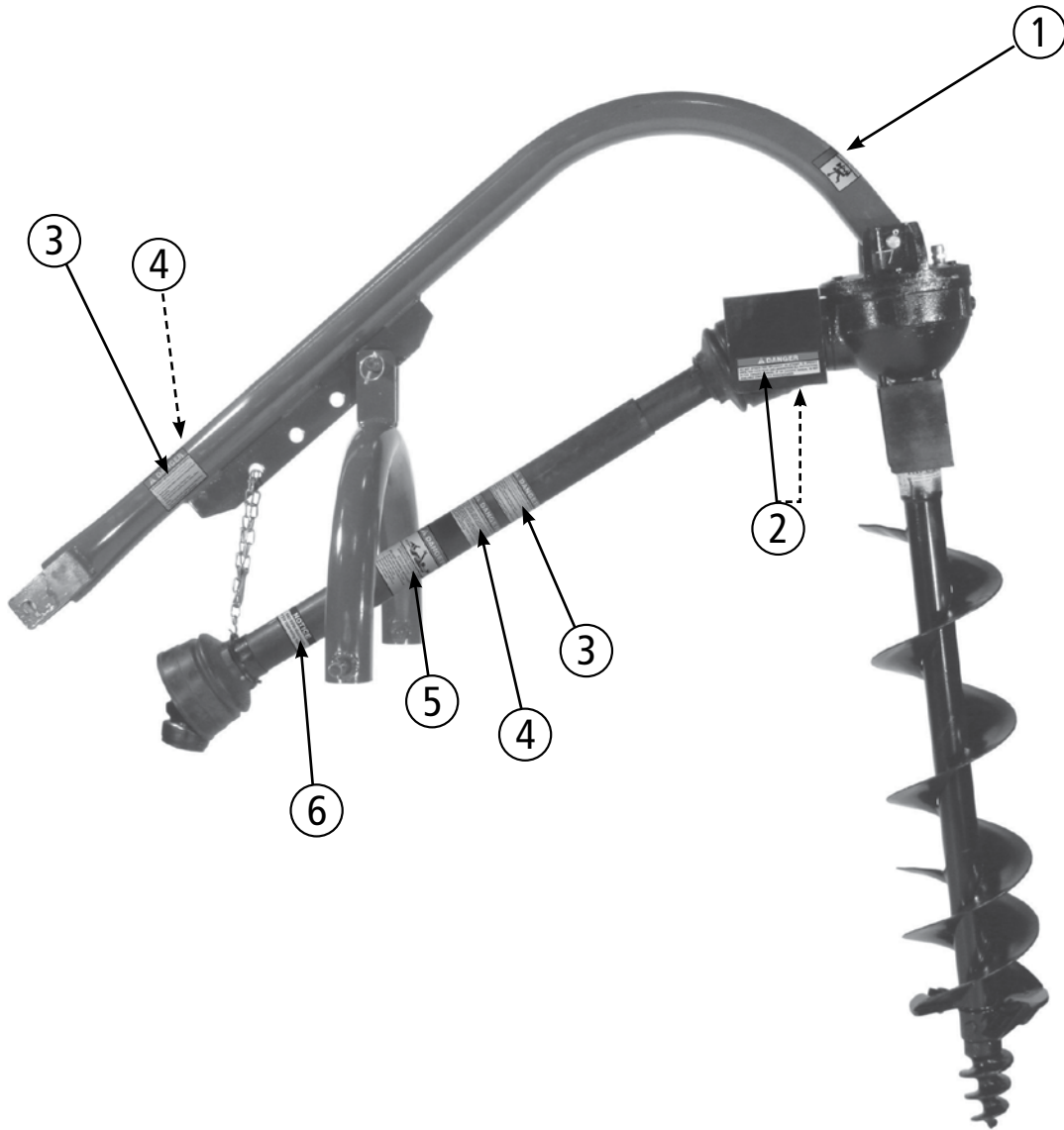

ATTENTION! BECOME ALERT! YOUR SAFETY IS INVOLVED!

Replace Immediately if Damaged!



① **ROTATING PARTS**

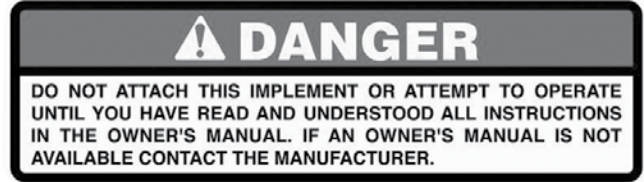

② **OWNERS MANUAL**



③ **SERIOUS INJURY**



④ **SERIOUS INJURY**



⑤ **ROTATING DRIVELINE**



⑥ **PTO SPEED**

ASSEMBLY AND SETUP

ASSEMBLING

NOTE: For safety, two(2) people recommended for assembling post hole digger.

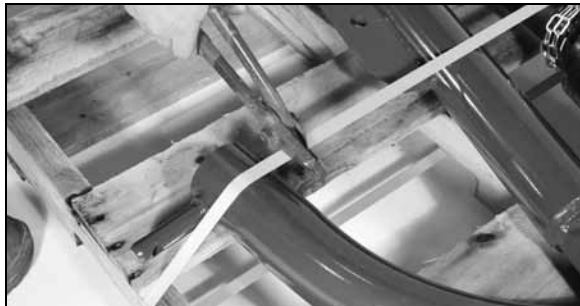

1. Place palletized post hole digger on level ground and cut the bands.



2. Attach the boom to the top link mounting bracket on the tractor using a top link pin and a lynch pin through the hole at the bottom of the boom.



3. Connect the "A" frame to the tractor's 3-point lift arms using the 7/8" pull pins with nut and lockwasher.



4. Remove the top link pin from the "A" frame. Attach the "A" frame to the boom after selecting the desired hole (for angle adjustment) using the 2-3/4" top link and 7/16" lynch pin.

5. Raise the 3-point high enough to have room for auger installation.



6. Using a 9/16" wrench, remove shear bolt. Use a hex screwdriver to back off set screw for jam nut enough to clear the internal bore of the PTO shaft.



7. Attach the auger to the output shaft on the bottom of the gear box using 1/2" x 3" hex cap Grade 5 screws, 1/2" lockwashers and 1/2" hex nuts. Tighten the nuts using provided ratchet holes if needed.

(continued on next page)

(continued from previous page)



8. Attach the driveline to the gear box input shaft using the 5/16" Grade 5 hex cap screw, the 5/16" lockwasher and the 5/16" NC hex nut. Tighten the hex nut. Insert the 1/4" x 3/8" set screw from the hardware kit in the hole on the yoke that aligns with the 3/16" groove on the gear box input shaft. Tighten.

ATTENTION The 3/8" hex cap screw provides shear protection. Use a Grade 2 3" bolt only to avoid damage to the gear box or auger.

IMPORTANT The universal joint should be greased with a good grade chassis lube every week. At the beginning of each season grease the sliding driveshaft members with a moly grease. All diggers are equipped with quick-detach universal joints on the PTO end for a 1-3/8" splined shaft.



9. Attach the tractor end of the driveline to the tractor PTO shaft. Push in the spring-loaded pin in the splined yoke and slip it on the splined PTO shaft of the tractor. Release the pin and push until it locks securely in place. It will be necessary to obtain a 1-1/8" to 1-3/8" sleeve spline adapter if your tractor PTO shaft has a 1-1/8" spline.



10. Attach and secure both chains on the driveline to the boom.

NOTE: When the 7/8" diameter pull pins in the "A" frame are too small for the holes in the lift arms, bushings should be used to obtain a proper fit.

IMPORTANT The gearbox is shipped without lubricant. Refer to the **BEFORE PUTTING POST HOLE DIGGER INTO SERVICE** section for proper service.

NOTE: An auger adapter is available for augers with a 2 5/8" input. Contact your dealer for more information.

ASSEMBLY AND SETUP

BEFORE PUTTING POST HOLE DIGGER INTO SERVICE



Always perform maintenance operations with the tractor engine off, the PTO drive disengaged and the auger point resting on the ground.

IMPORTANT: This post hole digger was shipped without oil in gearboxes. UNIT MUST BE SERVICED BEFORE USING.

NOTE: Fill gearbox using gear oil (type 80W-90 lubricant and fill to oil level plug). Check gear box every fifty hours of use to assure adequate lubrication.

NOTE: Check all nuts and bolts for tightness. Stabilizers should be kept tight to avoid side sway of the digger.



4. Fill gearbox in front using gear oil until oil begins to overflow from check plug hole in rear.



DO NOT overfill gearbox. This could cause damage to oil seals and can cause permanent damage to the gearbox. This issue will not be covered under warranty.

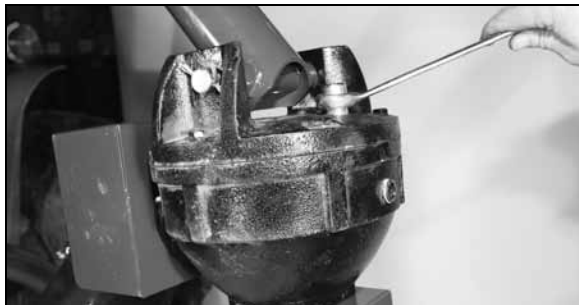

2. Using 7/8" wrench, remove 1/2" vented pipe plug located on front of gearbox above PTO shaft.



5. Replace and tighten the check plug.



3. Remove check plug located at back of gearbox.

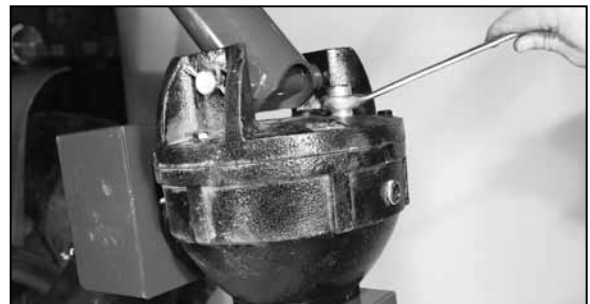

6. Replace and tighten the 1/2" vented pipe plug and clean away any excess oil.

ATTACHING TO TRACTOR

Never stand between tractor and post hole digger while backing up tractor to the hitch.

NOTE: For safety, two(2) people recommended for attaching post hole digger.

1. Place tractor and post hole digger on level ground and inspect for defects make sure all guards and shields are in place.
2. Set the digger in an upright position on the ground. While one person carefully balances the digger the other person attaches the boom to the top link mounting bracket and "A" frame to the lift arms on the tractor.
3. Raise the post hole digger to allow enough room to install the auger. Attach auger to the to the bottom of the gearbox.
4. Attach the PTO driveline to the tractor and to digger's gearbox input shaft and secure the anti-rotation chains.
5. Determine if the PTO shaft needs to be shortened.

NOTE: Due to the many variations in the tractor hitch points and distances between equipment gearbox input shaft and tractor PTO output shafts, some combinations may require PTO shafts to be shortened as described by the following steps.

6. Raise and lower digger in order to locate the shortest distance between equipment gearbox input shaft and tractor PTO output shaft. With the post hole digger in the shortest distance position shut down the tractor and SECURE THE POST HOLE DIGGER IN POSITION.
7. Pull apart PTO shaft and attach outer section to tractor PTO output shaft.

NOTE: Be sure to pull on PTO shaft section to ensure yoke has locked into place.

8. Place and hold inner PTO shaft section next to outer section and check if PTO shaft is too long. Each section should end approximately 3 inches short of reaching u-joint shield on the opposite section. If the shaft is too long measure 3 inches back from each u-joint shield and mark the other shaft section. Be sure to do this for both PTO shaft halves.

NOTE: Do not cut PTO shaft sections at this time.

9. Raise post hole digger. Raise and lower post hole digger in order to locate the longest distance between equipment input shaft and the tractor PTO output shaft. With the post hole digger in the longest distance position shut down the tractor and SECURE THE POST HOLE DIGGER IN POSITION.

10. As in step 5 hold PTO shaft sections together and check for a minimum of 6 inches of overlap. If PTO shaft has been marked for cutting the overlap is the distance measured between the two marks. If the PTO shaft has less than a 6 inch overlap, DO NOT USE. Contact your dealer for replacement.

NOTE: If the PTO shaft length is too long go to SIZING PTO SHAFT on the next page.

11. Apply any multi-purpose grease to the outside of the male (inner) PTO shaft section. Assemble PTO shaft and install on the digger and tractor.
12. Pull on tractor side of PTO shaft yoke to be sure it has locked in place. Make certain PTO shaft shielding is in place and good working condition.
13. The PTO shaft shield is a non-rotating design and must be secured prior to equipment use. Using the chain on each yoke shield attach to a fixed object on the tractor and equipment ends that will not allow the PTO shaft shield to rotate during operation.

DETACHING / SIZING PTO

DETACHING FROM TRACTOR

NOTE: For safety, two(2) people recommended for detaching post hole digger.

CAUTION

To prevent personal injury caused by unexpected movement:

- a. Park machine on a level surface.
- b. Engage tractor parking brake and/or place transmission in "Park".
- c. Disengage PTO.
- d. Shut off tractor engine and remove key.

1. Remove PTO driveline from the tractor and digger gearbox.

DANGER

Shut off tractor engine before detaching PTO driveline. Entanglement in rotating driveline can cause serious injury or death.

2. Adjust the post hole digger to allow room for auger removal. Remove auger from the bottom of gearbox.
3. Lower the post hole digger boom by using the lift arms on the tractor. Detach the boom from the top link mounting bracket and lift arms.
4. Carefully lay the post hole digger on the ground in a secure position.

SIZING THE PTO SHAFT

1. Cutting the PTO shaft to length.

NOTE: Be sure to cut equal lengths of each PTO shaft section. Clamp end of PTO shaft in a vice and cut off shield where marked. (Figure A & B)



Figure A



Figure B

2. Using cut section of the shield as a guide cut shaft off the same amount.



3. Repeat steps 1 and 2 for other PTO shaft section.
4. Use a file to deburr PTO shafts. Clean up all chips, burrs and filings from both ends of the PTO shaft.

OPERATING INSTRUCTIONS



WARNING

Read and thoroughly understand all instructions and safety information before operating this post hole digger. Failure to do so may cause serious injury or death. Do not allow anyone to operate this post hole digger who has not read this manual.

1. After mounting the digger to the tractor, lower the auger point slowly to the ground at the desired digging angle before engaging power.
2. Engage the PTO and start digging at a slow speed, lowering the auger slowly as it begins to dig.
3. Increase speed as the auger goes deeper. The type of soil will determine the proper auger speed. If the soil is extremely hard, it will generally improve operation to vary the speed of the auger at times. If an object is encountered which is too large for the auger to move, the digger will begin to vibrate. Withdraw the auger and remove the obstacle.
4. When the auger has reached the desired depth, spin it momentarily at a high speed to clear the hole of dirt. Reduce speed before withdrawing the auger from the hole.
5. Disengage the PTO after withdrawing the auger from the hole.

MAINTENANCE



WARNING

Always perform maintenance operations with the tractor engine off, the PTO drive disengaged and the auger point resting on the ground.

1. To remove the auger from the gear box output shaft, take out the two(2) 1/2" x 3-1/2" hex cap screws.
2. To remove the driveshaft from the gear box input shaft, take out the shear pin bolt and 1/4" set screw.
3. Check the oil level after every fifty hours of use. Use 80W- 90 lubricant and fill to oil level plug. All replacement lubricants should be of this type.
4. The universal joints should be greased with a good grade chassis lube every week. At the beginning of each season, grease the sliding driveshaft members with moly grease.

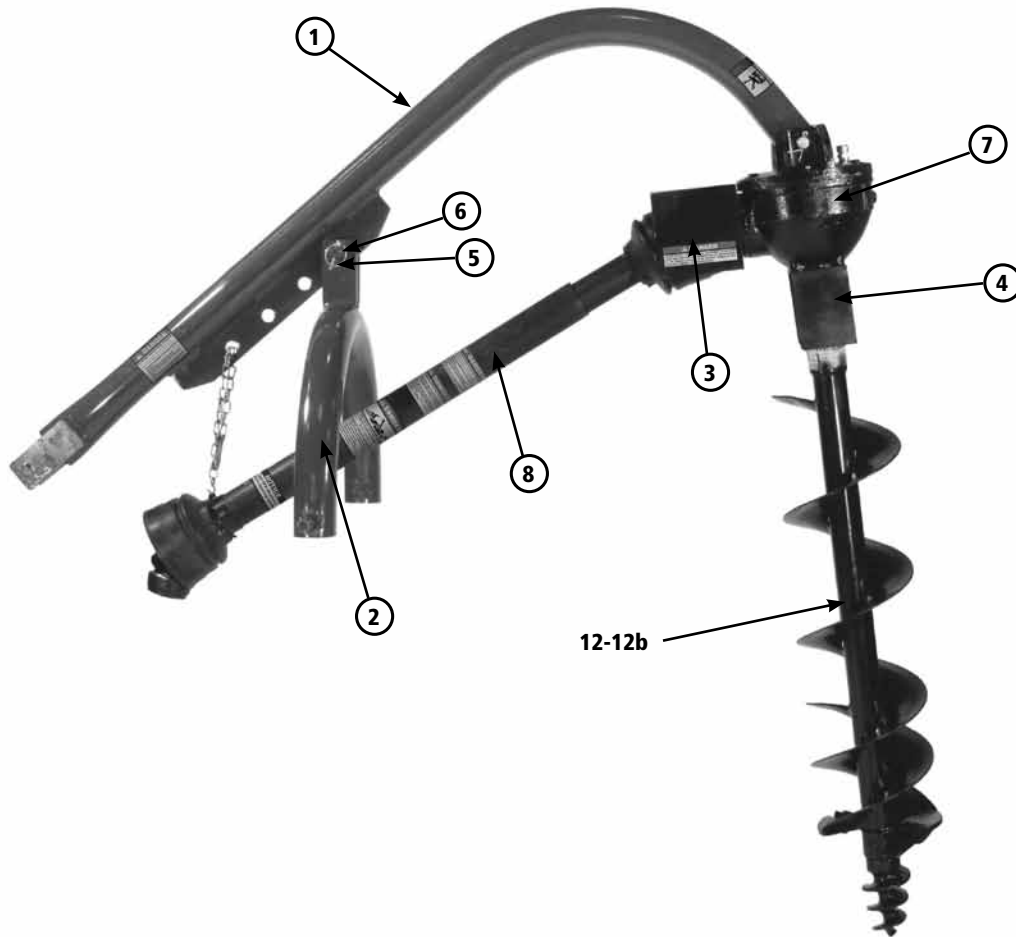

Post Hole Digger Parts List

Item Number	Part Number	Description
1	PHDTEA	Post Hole Digger Top End Assembly
2	PHDBEA	Post Hole Digger Bottom End Assembly
3	PTOSG	PTO Shaft Guard
4	DG	Drive Guard
5	716LP	7/16" Lynch Pin
6	TLP	Top Link Pin
7	PHDDGB	Post Hole Digger Gearbox
8	PHDPTO	Post Hole Digger PTO
9	PTOSDGH	PTO Shaft Guard & Drive Guard Hardware Kit (4pk) (Not Shown)
10	PHDPTOH	Post Hole Digger PTO Hardware (Not Shown)
11*	PHDABA	Auger Bit Adapter Kit (Not Shown)
12*	6A	6" Auger
12a*	9A	9" Auger
12b*	12A	12" Auger
13*	AH	Auger Hardware Kit (Not Shown)

* All Auger parts are ordered separately – Does not ship with unit.*

